

Parts Listing

Item	Qty	Description
1	1	Switch-Actuator Target Bracket
2	1	Main Mounting Bracket
3	2	Switch Mounting Bracket
4	3	5/16-18 x 3/4" Hex Head Cap Screw
5	5	5/16" Split Lock Washer
6	5	5/16" Flat Washer (0.75" OD)
7	4	M5 Hex Head Screw
8	4	M5 Hex Nut
9	4	M5 Lock Washer
10	8	M5 Flat Washer
11	2	5/8" Split Lock Washer
12	4	5/8-18 Jam Nut (supplied w/Companion)
13	2	5/16-18 Hex Nut (supplied w/Companion)
14	2	5/16" Split Lock Washer (supplied w/Companion)

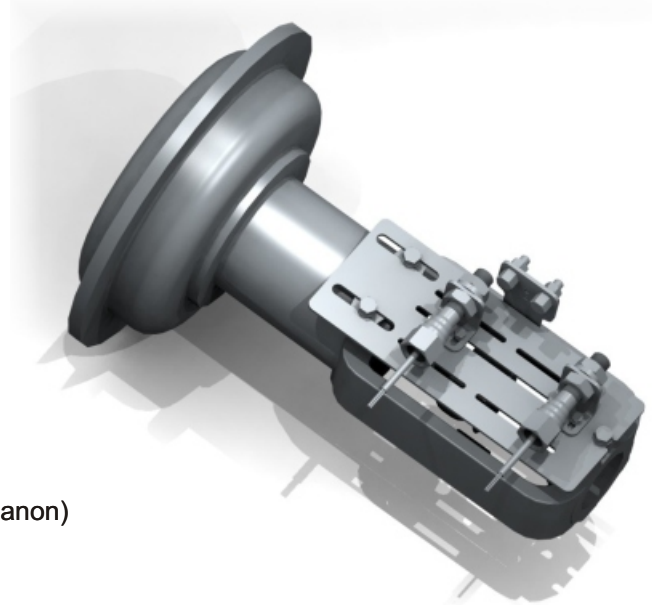

Mounting Instructions

1. Attach the switch-actuator target bracket (item 1) to the stem connector with the existing screws, and add the flat washers and lock washers (items 5 and 6).
2. Mount main bracket (item 2) to the actuator with items 4, 5 and 6
3. Mount switch mounting brackets (item 3) to main mounting bracket (item 1) with items 7,8,9 and 10.
4. Thread a Companion VPT through each switch mounting bracket (item 3) and secure with 2 jam nuts (item 12 - supplied with the Companion) and lock washer (item 11).
5. Mount the two magnetic triggers (supplied with the Companion) to the switch-actuator arm (item 1) with items 13 and 14 (supplied with the Companion).
6. Adjust the Companion switches on the main mounting bracket (item 2) and the magnetic triggers on the switch-actuator bracket (item 1) to the appropriate positions for the switches to sense each end of travel of the actuator.

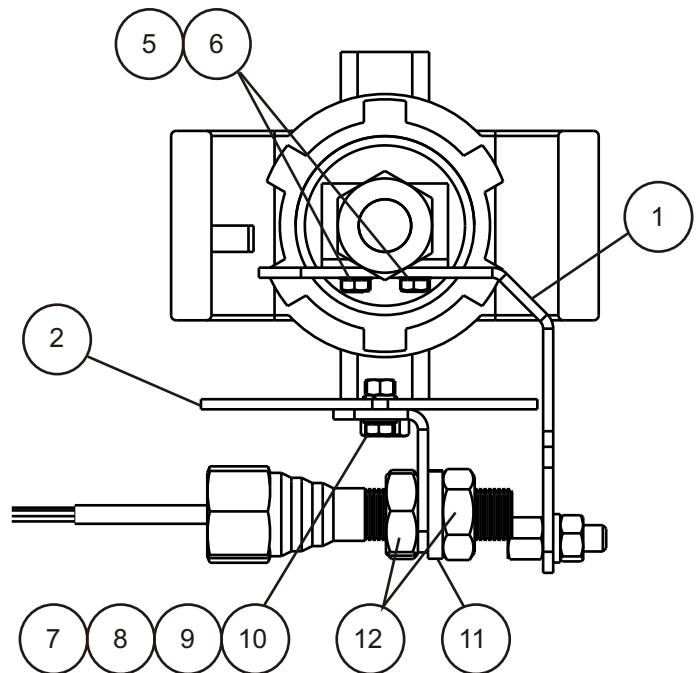
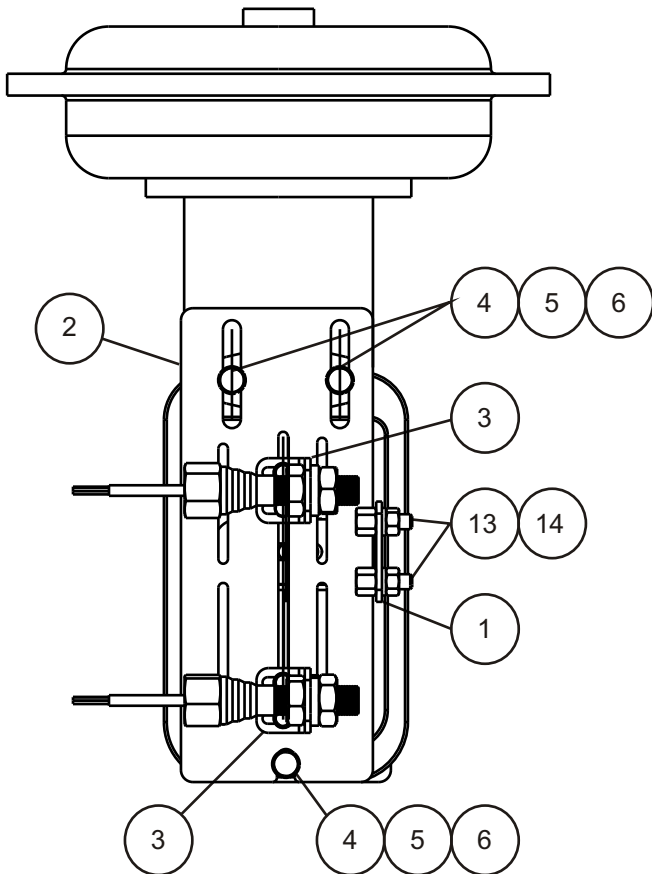

Exploded View

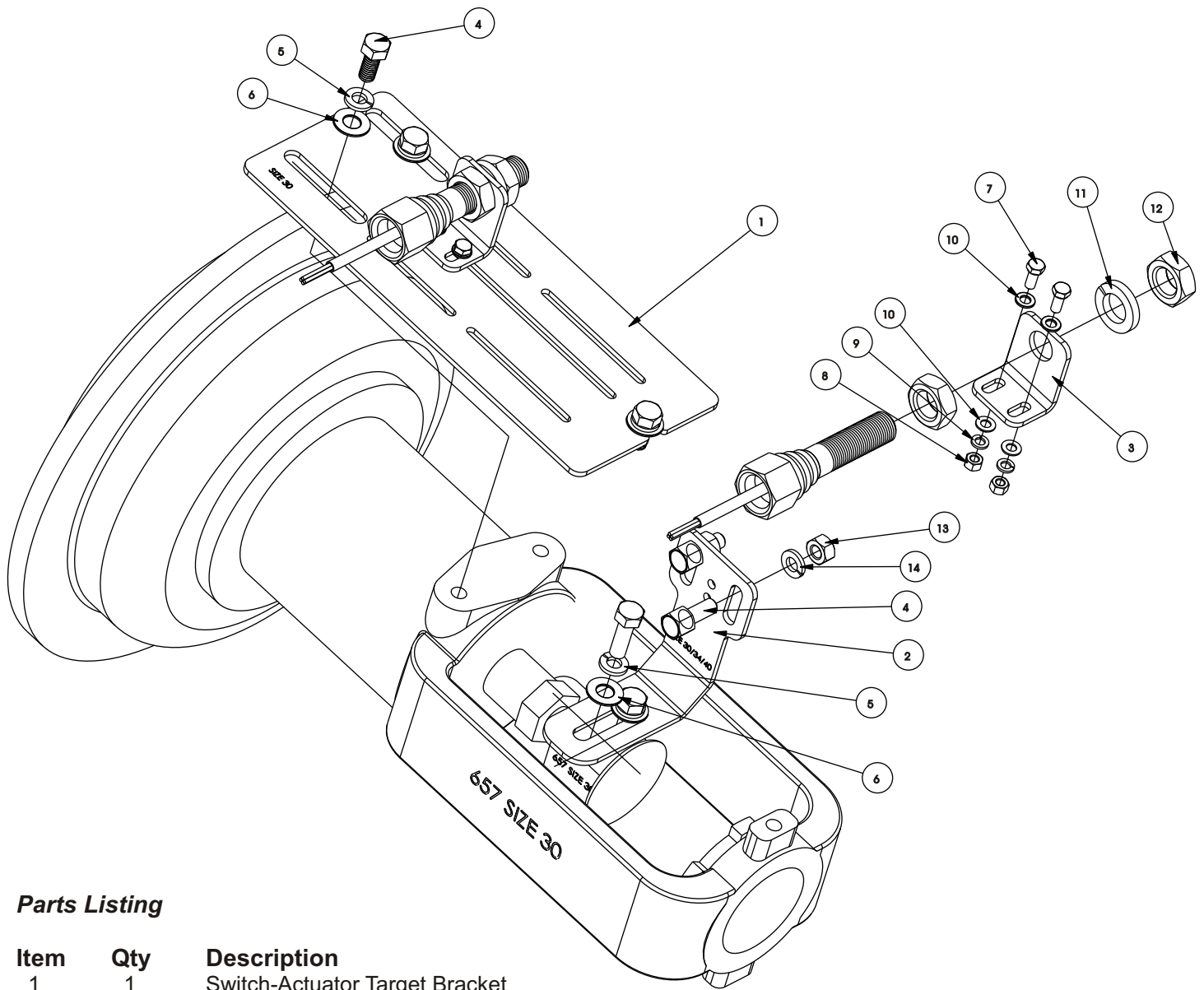

Parts Listing

Item	Qty	Description
1	1	Switch-Actuator Target Bracket
2	1	Main Mounting Bracket
3	2	Switch Mounting Bracket
4	3	5/16-18 x 3/4" Hex Head Cap Screw
5	5	5/16" Split Lock Washer
6	5	5/16" Flat Washer (0.75" OD)
7	4	M5 Hex Head Screw
8	4	M5 Hex Nut
9	4	M5 Lock Washer
10	8	M5 Flat Washer
11	2	5/8" Split Lock Washer
12	4	5/8-18 Jam Nut (supplied w/Companion)
13	2	5/16-18 Hex Nut (supplied w/Companion)
14	2	5/16" Split Lock Washer (supplied w/Companion)