

### Dimensions

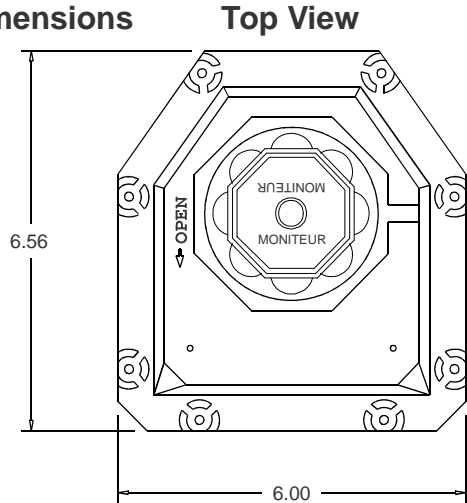

	NAMUR	STD.
A	0.156	0.249
B	0.62**	0.53



\* - FLAT COVER DIMENSION  
\*\* - LONG NAMUR = 1.28"

### Side View

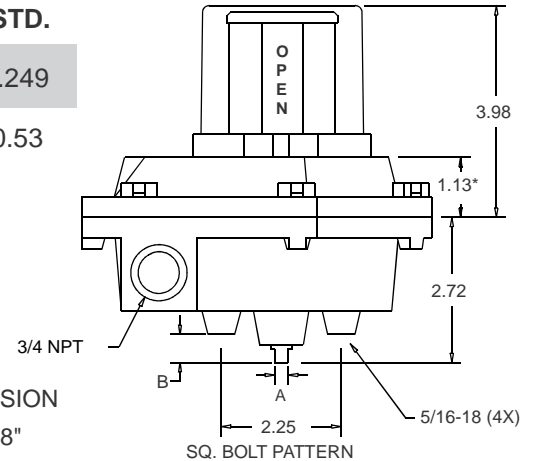

### General Specifications

Nema Rating	4, 4X, 7, 9
Housing / Cover	Aluminum
Indicator Cover	Ektar
Seals	BUNA-N
Fasteners	Stainless Steel
Terminal Points	8
Weight	4.25 lbs.
Operating Temp.	-40° F to 175° F

### How To Specify

Valve position transmitter shall be Moniteur model AMYB-ET20/AMYB-5T20/AMYB-1T20. Enclosure shall be aluminum with a polyurethane coating and rated Nema 4, 4X, 7, 9. Visual indicator shall have 100% display change, 360° visibility and full set point adjustability. Indicator cover shall be free of decals or paint and sealed with an O-ring. Enclosure shall have captive cover bolts. Enclosure shaft shall be attached to a sintered brass housing bearing with an internal stainless steel locking ring, environmentally protected with an O-ring. The switch/sensor type shall be Rhodium TTL Proximity Type rated 1A 24VDC/125VAC. All switches and terminals must be enclosed and individually marked for identification. Terminal strip must be angle-

### Wiring Diagram

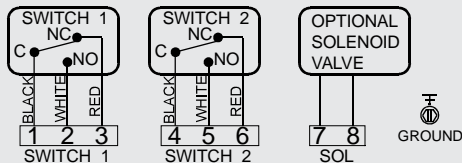

**Agency Approvals:** UL and CSA for  
Class I, Division 1, Groups C & D  
Class I, Division 2, Groups A & B  
Class II, Division 1, Groups E, F, G

### Part Number Description



Description	Code	Description	Code	Description	Code
<b>Series: Sentinel</b>	A	<b>Shaft</b>		<b>Switch Quantity</b>	2
<b>Cover</b>		Standard Shaft	1	<b>Conduit</b>	
With Moniteur	M	Low Profile NAMUR 303 SS	5	(2) 3/4" F NPT	0
<b>Moniteur</b>		NAMUR 303 SS	E		
Black/Yellow	Y	<b>Switch Type</b>			
<b>Bearing</b>		Rhodium TTL	T		
Bronze	B	Hermetically Sealed			
		Rhodium Non-Contact 1A			
		SPDT 24VDC/125VAC			